

Molex 55935-0210 PDF

molex[®]

深圳创唯电子有限公司 [http://www.molex-
connect.com](http://www.molex-connect.com)

1. 製品名称／PRODUCT NAME : 2.0 W/B CONN. PLUG HOUSING ASS'Y R/A

製品番号／PART NUMBER : 5 5 9 3 5 - * * 1 ☆

5 5 9 3 5 - * * 3 ☆

(* * は極数を示し、☆は色を示す。図面参照。)

(* * IS CIRCUITS SIZE. ☆ IS COLOR. REFER TO DRAWING.)

2. 標準梱包数／STANDARD PACKAGING QUANTITY

極 数 CKT. SIZE	プラスチックトレイ(15升) PLASTIC TRAY (15 POCKETS)	内装カートン PRIMARY CARTON		外装カートン SHIPPING CARTON
	1 トレイ製品数 QTY. IN ONE TRAY	トレイ枚数 NUMBER OF TRAYS	製品数 QUANTITY	製品数(内装カートン×4) QUANTITY (PRIMARY CARTON X4)
2	500	3	1,500	6,000
3	400	3	1,200	4,800
4	300	3	900	3,600
5	300	3	900	3,600
6	200	3	600	2,400
7	200	3	600	2,400
8	150	3	450	1,800
9	150	3	450	1,800
10	100	3	300	1,200
11	100	3	300	1,200
12	100	3	300	1,200
13	100	3	300	1,200
14	100	3	300	1,200
15	100	3	300	1,200

REV.	A		
SHEET	1~2		
REVISE ON PC ONLY		TITLE:	
A	RELEASED 110780 2016/11/24 Y.TOKUZONO		5 5 9 3 5 梱包仕様書 SALES PACKAGING SPEC. FOR 55935
	THIS DOCUMENT CONTAINS INFORMATION THAT IS PROPRIETARY TO MOLEX ELECTRONIC TECHNOLOGIES, LLC AND SHOULD NOT BE USED WITHOUT WRITTEN PERMISSION		
REV.	DESCRIPTION		
DESIGN CONTROL J		STATUS	DATE: 2016/11/24
WRITTEN BY: YTOKUZONO		CHECKED BY: K.TAKAHASHI	APPROVED BY: M.SASAO

DOCUMENT NUMBER 559359200	DOC. TYPE PS	DOC. PART 200	CUSTOMER GENERAL	SHEET 1 OF 2
------------------------------	-----------------	------------------	---------------------	-----------------

3. カートン外形参考寸法 / CARTON OUTER DIMENSIONS (REFERENCE PURPOSE ONLY) 単位 / UNIT: mm

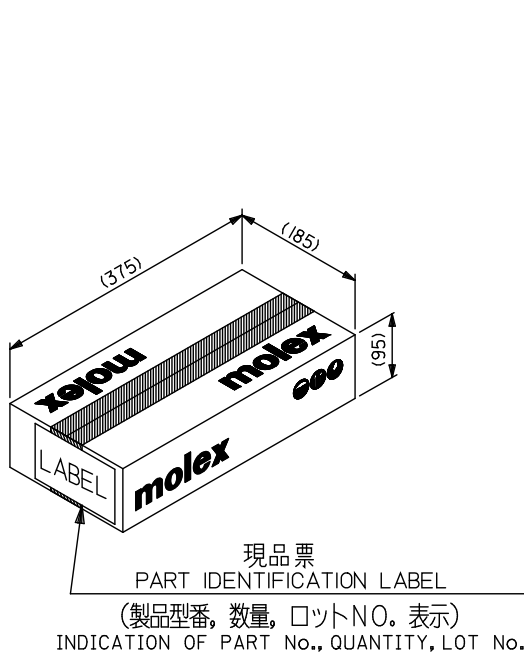

内装カートン
PRIMARY CARTON

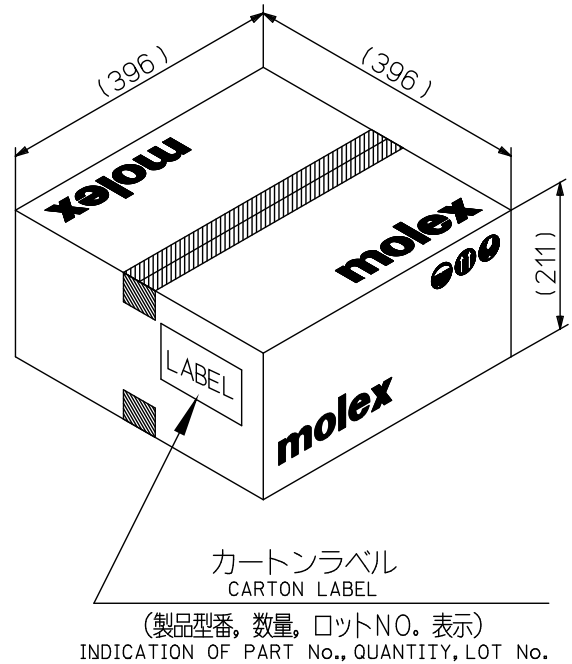

外装カートン
SHIPPING CARTON

REVISE ON PC ONLY		TITLE:			
A	SEE SHEET 1 OF 2	5 5 9 3 5 梱包仕様書 SALES PACKAGING SPEC. FOR 55935			
	REV. DESCRIPTION	THIS DOCUMENT CONTAINS INFORMATION THAT IS PROPRIETARY TO MOLEX ELECTRONIC TECHNOLOGIES, LLC AND SHOULD NOT BE USED WITHOUT WRITTEN PERMISSION			
DOCUMENT NUMBER 559359200		DOC. TYPE PS	DOC. PART 200	CUSTOMER GENERAL	SHEET 2 OF 2



PRODUCT SPECIFICATION



LANGUAGE

JAPANESE
ENGLISH

[1. 適用範囲 SCOPE]

本仕様書は、
 殿 に納入する
 2.0mm ピッチ プリント基板用コネクタ について規定する。
 This specification covers the 2.0mm P.C BOARD CONNECTOR series.

[2. 製品名称及び型番 PRODUCT NAME AND PART NUMBER]

製品名称 Product Name	無鉛 LEAD FREE	製品型番 Part Number
リセプタクル ターミナル Receptacle Terminal	無鉛 LEAD FREE	5 6 1 3 4 - 9 * 0 0
プラグ ハウジングアッセンブリ ストレート Plug Housing Assembly ST	無鉛 LEAD FREE	5 5 9 3 2 - * * * *
プラグ ハウジングアッセンブリ ライトアングル Plug Housing Assembly R/A	無鉛 LEAD FREE	5 5 9 3 5 - * * * *
リセプタクル ハウジング Receptacle Housing	無鉛 LEAD FREE	5 1 3 8 2 - * * * *

* : 図面参照 Refer to the drawing.

[3. 定格及び適用電線 RATINGS AND APPLICABLE WIRES]

項目 Item	規格 Standard	
最大許容電圧 Rated Voltage(MAX.)	250 V	
最大許容電流 及び適用電線 Rated Current (MAX.) and Applicable wires	AWG#22	3.0 A
	AWG#24	2.5 A
	AWG#26	2.5 A
	AWG#28	1.0 A
使用温度範囲 Ambient Temperature Range	- 25°C ~ + 85°C*1 低温において氷結しないこと Not freeze to low temperature	

*1 : 通電による温度上昇分も含む。

REV.	E	F	G										
SHEET	1-12	1-10	1-10										
REVISE ON PC ONLY						TITLE:							
G	変更 REVISED J2005-2744 '05/03/22 N.ITO					2.0mm PITCH W-t-B CONN. SINGLE -LEAD FREE- 製品仕様書							
	THIS DOCUMENT CONTAINS INFORMATION THAT IS PROPRIETARY TO MOLEX INC. AND SHOULD NOT BE USED WITHOUT WRITTEN PERMISSION												
REV.	DESCRIPTION			DESIGN CONTROL	STATUS	WRITTEN BY:	CHECKED BY:	APPROVED BY:	DATE: YR/MO/DAY				
	J					N.ITO	K.ASAKAWA	T.YAMAGUCHI	2005/03/22				
DOCUMENT NUMBER						FILE NAME						SHEET	
PS-51382-004						PS51382004.DOC						1 OF 10	
													EN-37-1(019)



PRODUCT SPECIFICATION



LANGUAGE

JAPANESE
ENGLISH

Including terminal temperature rise.

[4. 性能 PERFORMANCE]

4 - 1. 電気的性能 Electrical Performance

項目 Item	条件 Test Condition	規格 Requirement
4-1-1 接触抵抗 Contact Resistance	コネクタを嵌合させ、開放電圧 20mV 以下、短絡電流 10mAにて測定する。 (JIS C5402 5.4) Mate connectors ,measure by dry circuit, 20mV MAX., 10mA. (JIS C5402 5.4)	20 milliohm MAX.
4-1-2 絶縁抵抗 Insulation Resistance	コネクタを嵌合させ、隣接するターミナル間及びターミナル、アース間に、DC 500V を印加し測定する。 (JIS C5402 5.2/MIL-STD-202 試験法 302) Mate connectors, apply 500V DC between adjacent terminal or ground. (JIS C5402 5.2/MIL-STD-202 Method 302)	1000 Megohm MIN.
4-1-3 耐電圧 Dielectric Strength	コネクタを嵌合させ、隣接するターミナル間及びターミナル、アース間に、AC(rms)1000V (実効値)を1分間 印加する。 (JIS C5402 5.1/MIL-STD-202 試験法 301) Mate connectors, apply 1000V AC(rms) for 1 minute between adjacent terminal or ground. (JIS C5402 5.1/MIL-STD-202 Method 301)	異常なきこと No Breakdown
4-1-4 圧着部接触抵抗 Contact Resistance On Crimped Portion	ターミナルに適合電線を圧着し、開放電圧20mV 以下、短絡電流 10mA にて測定する。 Crimp the applicable wire on to the terminal, measure by dry circuit, 20mV MAX., 10mA.	5 milliohm MAX.

REVISE ON PC ONLY

G

SEE SHEET 1 OF 10

TITLE:

2.0mm PITCH W-t-B CONN. SINGLE

-LEAD FREE-

製品仕様

REV.

DESCRIPTION

THIS DOCUMENT CONTAINS INFORMATION THAT IS PROPRIETARY TO MOLEX INC. AND SHOULD NOT BE USED WITHOUT WRITTEN PERMISSION

DOCUMENT NUMBER

PS-51382-004FILE NAME
PS51382004.DOCSHEET
2 OF 10



PRODUCT SPECIFICATION



LANGUAGE

JAPANESE
ENGLISH

4 - 2. 機械的性能 Mechanical Performance

項目 Item	条件 Test Condition		規格 Requirement
4-2-1 挿入力及び抜去力 Insertion and Withdrawal Force	毎分 25±3mm の速さで挿入、抜去を行なう。 Insert and withdraw connectors at the speed rate of 25±3mm/minute.		第 6 項 参 照 Refer to paragraph 6
4-2-2 圧着部引張り強度 Crimping Pull Out Force	圧着されたターミナルを治具に固 定し、電線を軸方向に毎分25± 3mm の速さで引張る。 (JIS C5402 6.8) Fix the crimped terminal, apply axial pull out force on the wire at the speed rate of 25±3mm/minute. (JIS C5402 6.8)	AWG.#22	39.2 N { 4.0 kgf } MIN.
		AWG.#24	29.4 N { 3.0kgf } MIN.
		AWG.#26	19.6N {2.0 kgf } MIN.
		AWG.#28	9.8 N {1.0 kgf } MIN.
4-2-3 ターミナル挿入力 Terminal Insertion Force	圧着されたターミナルをハウジングに挿入す る。 Insert the crimped terminal into the housing.		9.8 N {1.0 kgf} MAX.
4-2-4 ターミナル保持力 Terminal / Housing Retention Force	圧着されたターミナルをハウジングに装着し、 電線を軸方向に毎分 25±3mm の速さで引っ張 る。 Apply axial pull out force at the speed rate of 25±3mm/minute on the terminal assembled in the housing.		9.8 N {1.0 kgf} MIN.
4-2-5 ピン保持力 Pin retention Force	毎分25±3mmの速さでピンを軸方向に押す。 Apply axial push force at the speed rate of 25±3mm / minute.		9.8 N {1.0 kgf} MIN.
4-2-6 強制抜去力 Compulsion Withdrawal Force	コネクタを嵌合させ、ロックを解除せずに 毎分25±3mmの速さで軸方向に引っ張る。 (試験サンプルは、端子装着状態とする。) Mate connectors, apply axial pull out force at the speed rate of 25±3mm / minute when it not discharge lock.		5 極以下 19.6N {2.0 kgf } MIN. 6 極以上 29.4 N { 3.0kgf } MIN.

REVISE ON PC ONLY

G

SEE SHEET 1 OF 10

TITLE:

2.0mm PITCH W-t-B CONN. SINGLE

-LEAD FREE-

製品仕様

REV.

DESCRIPTION

THIS DOCUMENT CONTAINS INFORMATION THAT IS PROPRIETARY TO
MOLEX INC. AND SHOULD NOT BE USED WITHOUT WRITTEN PERMISSION

DOCUMENT NUMBER

PS-51382-004FILE NAME
PS51382004.DOCSHEET
3 OF 10

EN-37-1(019)



PRODUCT SPECIFICATION



LANGUAGE

JAPANESE
ENGLISH

(Test sample have pin/terminal.)

4 - 3. その他 Environmental Performance and Others

項目 Item	条件 Test Condition	規格 Requirement	
4-3-1 繰返し挿抜 Repeated Insertion/ Withdrawal	1分間10回以下の速さで挿入、抜去を30回繰返す。 When mated up to 30 cycles repeatedly by the rate of 10 cycles per minute.	接触抵抗 Contact Resistance	40 milliohm MAX.
4-3-2 温度上昇 Temperature Rise	コネクタを嵌合させ、最大許容電流を通電し、コネクタの温度上昇分を測定する。 (UL 498) Carrying rated current load. (UL498)	温度上昇 Temperature-rise	30 °C MAX.
4-3-3 耐振動性 Vibration	DC1mA通電状態にて、嵌合軸を含む互いに垂直な3方向に掃引割合10~55~10 Hz/分 全振幅1.5mmの振動を各2時間加える。 (MIL-STD-202 試験法 201) Amplitude : 1.5mm P-P Sweep time : 10~55~10 Hz in 1 munute Duration : 2 hours in each X.Y.Z axes (MIL-STD-202 Method 201)	外観 Appearance	異常なきこと No Damage
		接触抵抗 Contact Resistance	40 milliohm MAX.
		瞬断 Discontinuity	1 microsecond MAX.
4-3-4 耐衝撃性 Shock	DC1mA通電状態にて、嵌合軸を含む互いに垂直な6方向に490m/s ² {50G}の衝撃を各3回加える。 (JIS C0041/MIL-STD-202 試験法 213) 490m/s ² {50G}, 3 strokes in each X.Y.Z. axes. (JIS C0041/MIL-STD-202 Method 213)	外観 Appearance	異常なきこと No Damage
		接触抵抗 Contact Resistance	40 milliohm MAX.
		瞬断 Discontinuity	1 microsecond MAX.

REVISE ON PC ONLY

G

SEE SHEET 1 OF 10

TITLE:

2.0mm PITCH W-t-B CONN. SINGLE

-LEAD FREE-

製品仕様

REV.

DESCRIPTION

THIS DOCUMENT CONTAINS INFORMATION THAT IS PROPRIETARY TO MOLEX INC. AND SHOULD NOT BE USED WITHOUT WRITTEN PERMISSION

DOCUMENT NUMBER

PS-51382-004

FILE NAME

PS51382004.DOC

SHEET

4 OF 10

EN-37-1(019)



PRODUCT SPECIFICATION



LANGUAGE

JAPANESE
ENGLISH

項目 Item		条件 Test Condition	規格 Requirement	
4-3-5	耐熱性 Heat Resistance	コネクタを嵌合させ、85±2℃の雰囲気中に96時間放置後取り出し、1～2時間室温に放置する。 (JIS C0021/MIL-STD-202 試験法108) 85±2℃, 96hours (JIS C0021/MIL-STD-202 Method 108)	外観 Appearance	異常なきこと No Damage
			接触抵抗 Contact Resistance	40 milliohm MAX.
4-3-6	耐寒性 Cold Resistance	コネクタを嵌合させ、-40±3℃の雰囲気中に96時間放置後取り出し、1～2時間室温に放置する。 (JIS C0020) -40±3℃, 96hours (JIS C0020)	外観 Appearance	異常なきこと No Damage
			接触抵抗 Contact Resistance	40 milliohm MAX.
4-3-7	耐湿性 Humidity	コネクタを嵌合させ、40±2℃、相対湿度90～95%の雰囲気中に96時間放置後取り出し、1～2時間室温に放置する。 (JIS C0022/MIL-STD-202 試験法103) Temperature : 40±2℃ Relative Humidity : 90~95% Duration : 96 hours (JIS C0022/MIL-STD-202 Method 103)	外観 Appearance	異常なきこと No Damage
			接触抵抗 Contact Resistance	40 milliohm MAX.
			耐電圧 Dielectric Strength	4-1-3項満足のこと Must meet 4-1-2
			絶縁抵抗 Insulation Resistance	100 Megohm MIN.
4-3-8	温度サイクル Temperature Cycling	コネクタを嵌合させ、-55℃に30分、+85℃に30分これを1サイクルとし、5サイクル繰返す。但し、温度移行時間は5分以内とする。 試験後1～2時間室温に放置する。 (JIS C0025) 5 cycles of: a) -55℃ 30minutes b) +85℃ 30minutes (JIS C0025)	外観 Appearance	異常なきこと No Damage
			接触抵抗 Contact Resistance	40 milliohm MAX.
			耐電圧 Dielectric Strength	4-1-3項満足のこと Must meet 4-1-2
			絶縁抵抗 Insulation Resistance	100 Megohm MIN.

REVISE ON PC ONLY

G

SEE SHEET 1 OF 10

TITLE:

2.0mm PITCH W-t-B CONN. SINGLE

-LEAD FREE-

製品仕様

REV.

DESCRIPTION

THIS DOCUMENT CONTAINS INFORMATION THAT IS PROPRIETARY TO MOLEX INC. AND SHOULD NOT BE USED WITHOUT WRITTEN PERMISSION

DOCUMENT NUMBER

PS-51382-004FILE NAME
PS51382004.DOCSHEET
5 OF 10



PRODUCT SPECIFICATION



LANGUAGE

JAPANESE
ENGLISH

項 目 Item		条 件 Test Condition	規 格 Requirement	
4-3-9	塩水噴霧 Salt Spray	コネクタを嵌合させ、 $35\pm 2^{\circ}\text{C}$ にて $5\pm 1\%$ 重量比の塩水を 48 ± 4 時間噴霧し、試験後常温で水洗いした後、室温で乾燥させる。 (JIS C0023/MIL-STD-202 試験法101) 48 ± 4 hours exposure to a salt spray from the $5\pm 1\%$ solution at $35\pm 2^{\circ}\text{C}$. (JIS C0023/MIL-STD-202 Method 101)	外観 Appearance	異状なきこと No Damage
			接触抵抗 Contact Resistance	40 milliohm MAX.
4-3-10	亜硫酸ガス SO ₂ Gas	コネクタを嵌合させ、 $40\pm 2^{\circ}\text{C}$ にて $50\pm 5\text{ppm}$ の亜硫酸ガス中に24時間放置する。 24 hours exposure to $50\pm 5\text{ppm}$. SO ₂ gas at $40\pm 2^{\circ}\text{C}$.	外観 Appearance	異状なきこと No Damage
			接触抵抗 Contact Resistance	40 milliohm MAX.
4-3-11	耐アンモニア性 NH ₃ Gas	コネクタを嵌合させ、濃度28%のアンモニア水を入れた容器中に40分間放置する。 (1Lに対して25mLの割合) 40 minutes exposure to NH ₃ gas evaporating from 28% Ammonia solution.	外観 Appearance	異状なきこと No Damage
			接触抵抗 Contact Resistance	40 milliohm MAX.

REVISE ON PC ONLY		TITLE:	
G	SEE SHEET 1 OF 10	2.0mm PITCH W-t-B CONN. SINGLE	
		-LEAD FREE- 製品仕様	
REV.	DESCRIPTION	THIS DOCUMENT CONTAINS INFORMATION THAT IS PROPRIETARY TO MOLEX INC. AND SHOULD NOT BE USED WITHOUT WRITTEN PERMISSION	
DOCUMENT NUMBER PS-51382-004		FILE NAME PS51382004.DOC	SHEET 6 OF 10



PRODUCT SPECIFICATION



LANGUAGE

JAPANESE
ENGLISH

項目 Item		条件 Test Condition	規格 Requirement	
4-3-12	半田付け性 Solderability	ターミナルをフラックスに浸し、本体の取付け基準面より1.6mm迄、 $245 \pm 3^{\circ}\text{C}$ の半田に 3±0.5秒浸す。 Soldering Time : $3 \pm 0.5 \text{ sec.}$ Solder Temperature : $245 \pm 3^{\circ}\text{C}$	濡れ性 Solder Wetting	浸漬面積の90%以上 90% of immersed area must show no voids, pin holes.
4-3-13	半田耐熱性 Resistance to Soldering Heat	(ディップの場合) <u>Soldering bath method</u> ターミナルまたはピンを本体の取付け基準面より1.6mm迄、 $260 \pm 5^{\circ}\text{C}$ の半田に5±0.5秒浸す。 Soldering Time : $5 \pm 0.5 \text{ sec.}$ Solder Temperature: $260 \pm 5^{\circ}\text{C}$	外観 Appearance	端子ガタ、割れ等 異状なきこと No Damage
		(手半田時) <u>Soldering iron method</u> 370~400°Cの半田ゴテにて 最大5秒加熱する。但し、端ピンに異常な加圧のないこと。 Solder Time : 5 sec MAX. Solder Temperature: $370 \sim 400^{\circ}\text{C}$ However, without too much pressure to the terminal pin.		

(): 参考規格 Reference Standard
{ }: 参考単位 Reference Unit

【5. 外観形状、寸法及び材質 PRODUCT SHAPE, DIMENSIONS AND MATERIALS】

図面参照 Refer to the drawing.

REVISE ON PC ONLY		TITLE:	
G	SEE SHEET 1 OF 10	2.0mm PITCH W-t-B CONN. SINGLE -LEAD FREE- 製品仕様	
	REV.	DESCRIPTION	THIS DOCUMENT CONTAINS INFORMATION THAT IS PROPRIETARY TO MOLEX INC. AND SHOULD NOT BE USED WITHOUT WRITTEN PERMISSION
DOCUMENT NUMBER PS-51382-004		FILE NAME PS51382004.DOC	SHEET 7 OF 10



PRODUCT SPECIFICATION



LANGUAGE

JAPANESE
ENGLISH

【 6. 挿入力及び抜去力 INSERTION/WITHDRAWAL FORCE 】

極数 No. of	単位	挿入力 (最大値) Insertion (MAX.)			抜去力 (最小値) Withdrawal (MIN.)		
		初回 1st	6回目 6th	30回目 30th	初回 1st	6回目 6th	30回目 30th
2	N {kgf}	23.0 {2.34}	31.0 {3.16}	31.0 {3.16}	0.9 {0.10}	0.4 {0.05}	0.4 {0.05}
3	N {kgf}	24.5 {2.50}	32.5 {3.31}	32.5 {3.31}	1.4 {0.15}	0.7 {0.08}	0.7 {0.08}
4	N {kgf}	26.0 {2.65}	34.0 {3.46}	34.0 {3.46}	1.9 {0.20}	0.9 {0.10}	0.9 {0.10}
5	N {kgf}	27.5 {2.80}	35.5 {3.62}	35.5 {3.62}	2.4 {0.25}	1.2 {0.13}	1.2 {0.13}
6	N {kgf}	29.0 {2.95}	37.0 {3.77}	37.0 {3.77}	2.9 {0.30}	1.4 {0.15}	1.4 {0.15}
7	N {kgf}	30.5 {3.11}	38.5 {3.92}	38.5 {3.92}	3.4 {0.35}	1.7 {0.18}	1.7 {0.18}
8	N {kgf}	32.0 {3.26}	40.0 {4.08}	40.0 {4.08}	3.9 {0.40}	1.9 {0.20}	1.9 {0.20}
9	N {kgf}	33.5 {3.41}	41.5 {4.23}	41.5 {4.23}	4.4 {0.45}	2.2 {0.23}	2.2 {0.23}
10	N {kgf}	35.0 {3.57}	43.0 {4.38}	43.0 {4.38}	4.9 {0.50}	2.4 {0.25}	2.4 {0.25}
11	N {kgf}	36.5 {3.72}	44.5 {4.54}	44.5 {4.54}	5.3 {0.55}	2.7 {0.28}	2.7 {0.28}
12	N {kgf}	38.0 {3.87}	46.0 {4.69}	46.0 {4.69}	5.8 {0.60}	2.9 {0.30}	2.9 {0.30}
13	N {kgf}	39.5 {4.03}	47.5 {4.84}	47.5 {4.84}	6.3 {0.65}	3.2 {0.33}	3.2 {0.33}
14	N {kgf}	41.0 {4.18}	49.0 {5.00}	49.0 {5.00}	6.8 {0.70}	3.4 {0.35}	3.4 {0.35}
15	N {kgf}	42.5 {4.33}	50.5 {5.15}	50.5 {5.15}	7.3 {0.75}	3.7 {0.38}	3.7 {0.38}

REVISE ON PC ONLY		TITLE:	
G	SEE SHEET 1 OF 10	2.0mm PITCH W-t-B CONN. SINGLE	
		-LEAD FREE- 製品仕様	
REV.	DESCRIPTION	THIS DOCUMENT CONTAINS INFORMATION THAT IS PROPRIETARY TO MOLEX INC. AND SHOULD NOT BE USED WITHOUT WRITTEN PERMISSION	
DOCUMENT NUMBER PS-51382-004		FILE NAME PS51382004.DOC	SHEET 8 OF 10



PRODUCT SPECIFICATION



LANGUAGE

JAPANESE
ENGLISH

【 7. 使用上の注意事項 OPERATIONAL PRACTICES 】

1. コネクタの嵌合を取り外す際は、必ずロックを解除して行ってください。
When unmated to connectors, positive locks shall be released.
2. 嵌合状態及び電線引き回し作業において、ロック部に無理な負荷がかかるような使用は避けて下さい。
When mating connectors and taking a harness around, connectors shall be used so that locks are free from direct excessive force.

	REVISE ON PC ONLY		TITLE: 2.0mm PITCH W-t-B CONN. SINGLE -LEAD FREE- 製品仕様
	G	SEE SHEET 1 OF 10	
REV.	DESCRIPTION		THIS DOCUMENT CONTAINS INFORMATION THAT IS PROPRIETARY TO MOLEX INC. AND SHOULD NOT BE USED WITHOUT WRITTEN PERMISSION
DOCUMENT NUMBER PS-51382-004			FILE NAME PS51382004.DOC
			SHEET 9 OF 10



PRODUCT SPECIFICATION



LANGUAGE

JAPANESE
ENGLISH

REV.	REV. RECORD	DATE	EC NO.	WRITTN:	CHK:
A	RELEASED	'02/03/08	J2002-2279	T.NITSU	K.ASAKAWA
B	REVISED	'02/04/26	J2002-2720	T.NITSU	K.ASAKAWA
C	REVISED	'02/05/15	J2002-2827	T.NITSU	K.ASAKAWA
D	REVISED	'02/06/19	J2002-3182	T.NITSU	K.ASAKAWA
E	REVISED	'03/06/12	J2003-3127	N.ITO	K.ASAKAWA
F	REVISED	'04/09/28	J2005-0931	E.SUZUKI	K.TOJO
G	REVISED	'05/03/22	J2005-2744	N.ITO	K.ASAKAWA

G	REVISE ON PC ONLY	TITLE: 2.0mm PITCH W-t-B CONN. SINGLE -LEAD FREE- 製品仕様
	SEE SHEET 1 OF 10	
REV.	DESCRIPTION	THIS DOCUMENT CONTAINS INFORMATION THAT IS PROPRIETARY TO MOLEX INC. AND SHOULD NOT BE USED WITHOUT WRITTEN PERMISSION
DOCUMENT NUMBER PS-51382-004		FILE NAME PS51382004.DOC
		SHEET 10 OF 10